

7 DEALER MANUAL FOR DP E180.CAN/ DP E181.CAN



CONTENT

7.1 Important Notice	2	7.7 Normal Operation	5
7.2 Introduction of Display	2	7.7.1 Power On/Off.....	5
7.3 Product Description	3	7.7.2 Switch Power Assisted Level.....	5
7.3.1 Overall Dimension.....	3	7.7.3 Switch the Headlight.....	6
7.3.2 Specifications.....	3	7.7.4 Walk Assistance.....	6
7.3.3 Function Overview.....	3	7.7.5 Battery Capacity Indication.....	6
7.4 Display Installation	4	7.7.6 Bluetooth Indication.....	6
7.5 Display	4	7.8 Error Code Definition	7
7.6 Key Definition	5		

7.1 IMPORTANT NOTICE

- If the error information from the display cannot be corrected according to the instructions, please contact your retailer.
- The product is designed to be waterproof. It is highly recommended to avoid submerging the display under water.
- Do not clean the display with a steam jet, high-pressure cleaner or water hose.
- Please use this product with care.
- Do not use thinners or other solvents to clean the display. Such substances can damage the surfaces.
- Warranty is not included due to wear and normal use and aging.

7.2 INTRODUCTION OF DISPLAY

- **Model:** DP E180.CAN
DP E181.CAN
- **Appearance:**



- **Identification:**

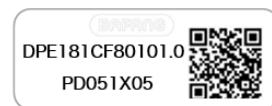

- **Note:** Please keep the QR code label attached to the display cable. The information from the Label is used for a later possible software update.

7.3 PRODUCT DESCRIPTION

7.3.1 Overall Dimension

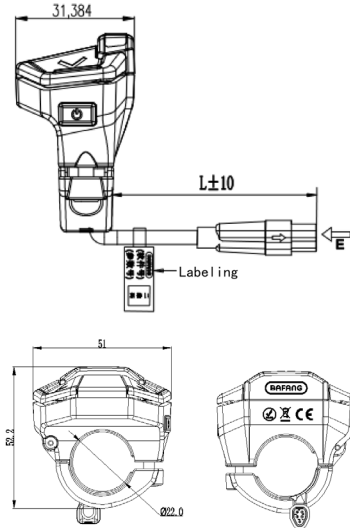

7.3.2 Specifications

- Operating temperature: $-20\text{ }^{\circ}\text{C} \sim 45\text{ }^{\circ}\text{C}$
- Storage temperature: $-20\text{ }^{\circ}\text{C} \sim 60\text{ }^{\circ}\text{C}$
- Waterproof: IPX5
- Bearing humidity: 30%-70% RH

7.3.3 Function Overview

- Battery capacity indication
- Power on and off
- Control and indication of power assistance
- Walk assistance
- Control of lighting system
- Automatic sensitivity to light
- Error code indication

7.4 DISPLAY INSTALLATION

1. Open the clamp of display and place the display cable into the groove.

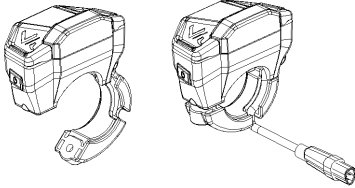

3. Dock the DP's male connector "h" with EB-BUS's female connector "H" as indicated.

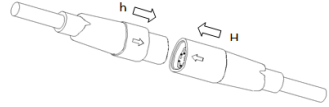

2. Put the clamp onto the handlebar, fix it with a M3*8 hex screw at tightening torque of 1 N.m.

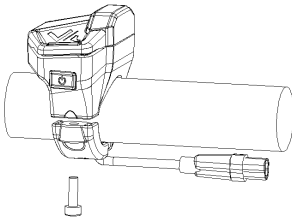

7.5 DISPLAY

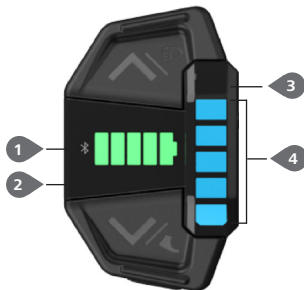

- 1 Bluetooth indication
(only light up in DP E181.CAN)
- 2 Battery capacity indication
- 3 AL sensitivity position
- 4 Power assistance indication
(level 1 to level 5 is from bottom to top, no LED light means no power assistance)
- 5 Error code indication
(LED lights of level 1 and level 2 flash at a frequency of 1Hz.)

7.6 KEY DEFINITION



7.7 NORMAL OPERATION

7.7.1 Power On/Off

Press and hold  (>2S) on the display to power on the system.

Press and hold  (>2S) again to power off the system.

In the off state, the leakage current is less than 1uA.

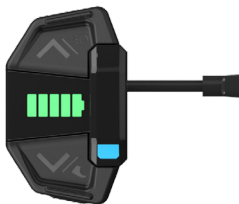

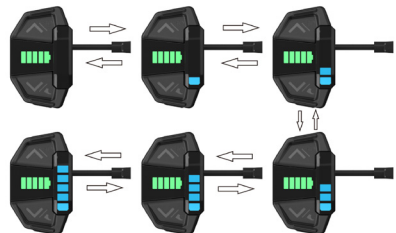

7.7.2 Switch Power Assisted Level

When the display is turned on, press  (<0.5S) to switch to the power assisted level and change the output power of the motor. The default level is level 0-5, of which the lowest is 1, the highest is 5, and level 0 is no power assistance.







7.7.3 Switch the Headlight

ON: Press and hold  (>2S) when the headlight is off, and the controller will switch on the headlight.

OFF: Press and hold  (>2S) when the headlight is on, and the controller will switch off the headlight.

7.7.4 Walk Assistance





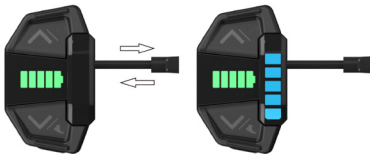

Press  (<0.5S) to the level 0 (no indication of the power assistance), then press  (>2S) to enter the walk assistance mode. Then press and hold  to start walk assistance.

In the walk assistance mode, 5 LED lights flash at a frequency of 1Hz and the real-time speed is less than 6km/h. Once releasing the  button, it will exit the walk assistance mode. If no operation within 5s, the display will automatically return to level 0.



7.7.5 Battery Capacity Indication

The battery capacity is indicated with 5 levels. When the lowest level indicator flashes that means battery needs to charge. The battery capacity is shown as follows:

Bars	Capacity Range	Example
5	$80\% \leq C \leq 100\%$	
4	$60\% \leq C < 80\%$	
3	$40\% \leq C < 60\%$	
2	$20\% \leq C < 40\%$	
1	$5\% \leq C < 20\%$	
LOW	<5%	

7.7.6 Bluetooth Indication

Note: Only DP E181.CAN is the Bluetooth version.

DP E181.CAN can be connected with BAFANG GO via Bluetooth, and all information can be shown on the smart phone, such as battery, sensor, controller and display.

The default name of Bluetooth is DP E181.CAN. After connecting, the Bluetooth indication on the display will be on.

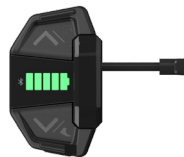

(Bafang Go for Android™ and iOS™)

7.8 ERROR CODE DEFINITION



The display can show the errors of a pedelec. When the fault is detected, the LED lights will flash at a frequency of 1Hz. The LED light of level 1 indicates the tens digit of the error code, while the LED light of level 2 indicates the unit digit. For example:

Error code 25 : The LED light of level 1 flickers for 2 times, and the LED light of level 2 flickers for 5 times.

Note: Please read carefully the description of the error code. When the error code appears, please first restart the system. If the problem is not eliminated, please contact your dealer or technical personnel.

See Appendix A for the detailed error code list.